

# ATS 10 SHOCK ABSORBENT TABLE STAND

## OVERVIEW:

The ATS series are shock mounted table stands designed for professional audio installations.

The ATS 10 is designed for use with dynamic gooseneck microphones or phantom powered gooseneck condenser microphones such as the Audix ADX series, MG series, and MGN series. The ATS 10 table stand features a heavy duty die cast base, noise free on-off switch, LED indicator, and standard XLR connectors for input and output. Designed for durability, stability, and high performance, the ATS 10 will bring an element of professionalism to any audio or A/V installation. Applications for the ATS 10 include conferencing, podium, lectern, classroom, courtroom, boardroom, and House of Worship.

## MODEL VARIATIONS:

ATS1 - Same as above with programmable on/off switch.

ATS1L - Same as ATS1 with logic.

## OPERATION: [Refer to figures below]

**Important:** Before connecting or disconnecting any of the audio cables to the ATS 10, be sure that the channel volume is off or muted on the mixing device.

To connect the microphone to the ATS 10 table stand, align the XLR pins of the microphone to the XLR pins on top of the base. Gently push down until the connectors “click” into place. [Figure 1].

To remove the microphone, press the tab on the top of the base to release the internal locking tab and the microphone can easily be pulled out of the connector. [Figure 2].

To connect the audio, use a balanced microphone cable and plug the XLRf connector into the XLRm connector on the back side of the ATS 10 base until it “clicks” into place. To disconnect the cable, press the tab on the microphone cable XLRf connector and pull the cable out. [Figure 3].

**On-off switch:** To activate the microphone, the switch will need to be pressed into the “on” position. When phantom power is present, the LED will turn red to indicate that the microphone is active. When the switch is the off position, the microphone will be muted and the LED will show no light. [Figure 4]

**Important:** Most gooseneck microphones are condenser microphones and require phantom power. For condenser microphones to operate, phantom power (11-52 volts) must be supplied to the microphone from either the mixing console or a phantom power supply (such as the Audix APS 2).



## FEATURES:

- Simple to operate
- Heavy Duty die cast metal base for gooseneck style microphones
- Noise free on-off switch with LED indicator
- Operates on 11 – 52 volts phantom power for condenser microphones
- Standard 3-pin XLR-type connector for microphone input and output
- Non reflective black matte finish

FIGURE 1



FIGURE 2



FIGURE 3



FIGURE 4



FIGURE 5



**SPECIFICATIONS:**

<b>On-Off Switch</b>	<b>Noise free mechanical push-on/push-off</b>
<b>Input connector</b>	<b>3-pin XLRf-type</b>
<b>Output connector</b>	<b>3-pin XLRm-type</b>
<b>Off (mute) attenuation</b>	<b>45 dB minimum</b>
<b>Phantom power requirements</b>	<b>11-52V DC, 2 mA</b>
<b>Finish</b>	<b>Black matte</b>
<b>Weight</b>	<b>1.4 kg / 3 pounds</b>
<b>Length</b>	<b>160 mm / 6.9 inches</b>
<b>Width</b>	<b>124 mm / 5.9 inches</b>
<b>Height</b>	<b>45 mm / 1.8 inches</b>

**ARCHITECTS AND ENGINEERS SPECIFICATIONS:**

The table stand shall be constructed from die cast metal base to provide maximum stability on a desk, podium, or table. The table stand shall be designed to work with any dynamic gooseneck or phantom powered condenser gooseneck microphone operating between 11-52 volts phantom and having a standard 3-pin XLRm connector. The table stand shall incorporate a noise free mechanical push on / push off which will provide minimum 45 dB of attenuation when in the "off" position. The table stand shall incorporate an LED light to indicate when the system is in the "on" mode. The table stand shall have a 3 pin XLR-f connector for audio input and a 3 pin XLR-m connector for output. The stand shall be finished in non-reflective matte black finish and have dimensions of 160 mm (6.3 inches) length, 124 mm (5.9 inches) width, and 45 mm (1.8 inches) maximum height. The table stand shall be the ATS 10.

**DIMENSIONS (mm):**

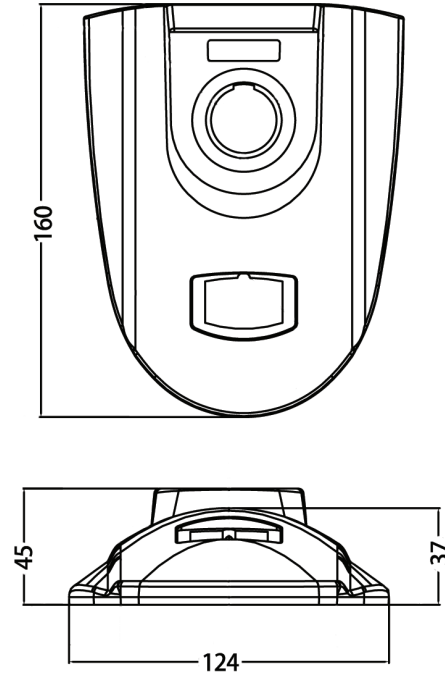

\*\*\*All specifications subject to change without notice.

**SERVICE AND WARRANTY:**

The ATS 10 is under warranty for a period of 1 year from any and all manufacturing defects. Should your microphone fail in any way, please contact the Audix Service department at 503-682-6933. A Return Authorization number is required before returning any products.



CALL: 503-682-6933 FAX: 503-682-7114 www.audixusa.com  
 Audix Corporation 9400 SW Barber St, Wilsonville, OR 97070. In Canada, Cabletek Electronics LTD, 604-942-1001 fax 604-942-1010  
 © Audix Corporation 2010. All rights reserved. Audix and the Audix logo are trademarks of Audix Corporation

ver. 1.1 - 11/11

**AUDIX WARRANTY REGISTRATION FORM**

Name: \_\_\_\_\_ Model: \_\_\_\_\_  
 Company: \_\_\_\_\_ Serial Number: \_\_\_\_\_  
 Address: \_\_\_\_\_ Store: \_\_\_\_\_  
 City: \_\_\_\_\_ Store Location: \_\_\_\_\_  
 Prov./State: \_\_\_\_\_ Zip: \_\_\_\_\_ Purchase Date: \_\_\_\_\_  
 Phone: ( ) \_\_\_\_\_ Signature: \_\_\_\_\_  
 Email: \_\_\_\_\_ Date: \_\_\_\_\_

Please Check all that apply:

Male  Female

Age:

- 18 or Under
- 19-25
- 26-35
- 36-45
- 46-55
- 55 +

Occupation:

- Musician
- Producer
- Sound Eng.
- Radio/TV
- Production
- Other \_\_\_\_\_

Primary Instruments:

- Vocal
- Guitar
- Drums
- Keyboard
- Brass
- Woodwinds
- Strings
- Other \_\_\_\_\_

Product to be used for:

- Pro live sound
- Pro recording
- Home recording
- Rehearsal
- Installation
- School
- House of Worship
- Other \_\_\_\_\_

How did you hear about Audix?

- Magazine Ad
- Online Ad
- On-line Store
- Friend
- Salesman
- Other \_\_\_\_\_

Do you own other Audix Products?  Yes  No

Model(s) \_\_\_\_\_

Have you visited the Audix website?  Yes  No

Please register your product online at [www.audixusa.com](http://www.audixusa.com) or mail this form to:  
 Audix Microphones ATTN: WARRANTY P.O. Box 4010 Wilsonville, OR 97070